

**FURZE
PLATT**
SENIOR SCHOOL



A-LEVEL COMPUTER SCIENCE

AMBITIOUS

COLLABORATIVE

HAPPY

INTEGRITY

ENDURANCE

VERSATILITY

EXCELLENCE

So, why study Computer Science?

- Computer Science involves using computational thinking skills to break down and solve problems in a systematic manner.
- In real life, for when you are presented with challenges, this skill is invaluable, in many careers in the field of Computer Science, from Software Design & Development and Database Administration to Project and Team Management.
- There is an increasing presence of technology in the day-to-day life and you will find over 82% of jobs involve technology in some way, and about 3 million people work in the technology field.

Skills / Qualities

- Self-Discipline
- Motivation
- Problem solving skills
- Good analysis skills
- Programming skills
- Resilience
- Reflection skills
- Listening skills

Could you convert this pseudocode into actual code?

```
PlayerOneScore = 0
PlayerTwoScore = 0
OUTPUT "How many games?"
INPUT NoOfGamesInMatch
FOR NoOfGamesPlayed = 1 TO NoOfGamesInMatch Do
    OUTPUT "Did Player One win the game (enter Y or N)?"
    INPUT PlayerOneWinsGame
    IF PlayerOneWinsGame = 'Y'
        THEN PlayerOneScore = PlayerOneScore + 1
        ELSE PlayerTwoScore = PlayerTwoScore + 1
    ENDIF
ENDFOR
OUTPUT PlayerOneScore
OUTPUT PlayerTwoScore
```

Python Code

```
# Initialize scores
PlayerOneScore = 0
PlayerTwoScore = 0

# Ask how many games in the match
NoOfGamesInMatch = int(input("How many games? "))

# Loop through each game
for NoOfGamesPlayed in range(1, NoOfGamesInMatch + 1):
    # Ask if Player One won the game
    PlayerOneWinsGame = input("Did Player One win the game (enter Y or N)? ").strip().upper()

    # Update scores based on input
    if PlayerOneWinsGame == 'Y':
        PlayerOneScore += 1
    else:
        PlayerTwoScore += 1

# Output the final scores
print("Player One Score:", PlayerOneScore)
print("Player Two Score:", PlayerTwoScore)
|
```

Simplify the combined logic gate?

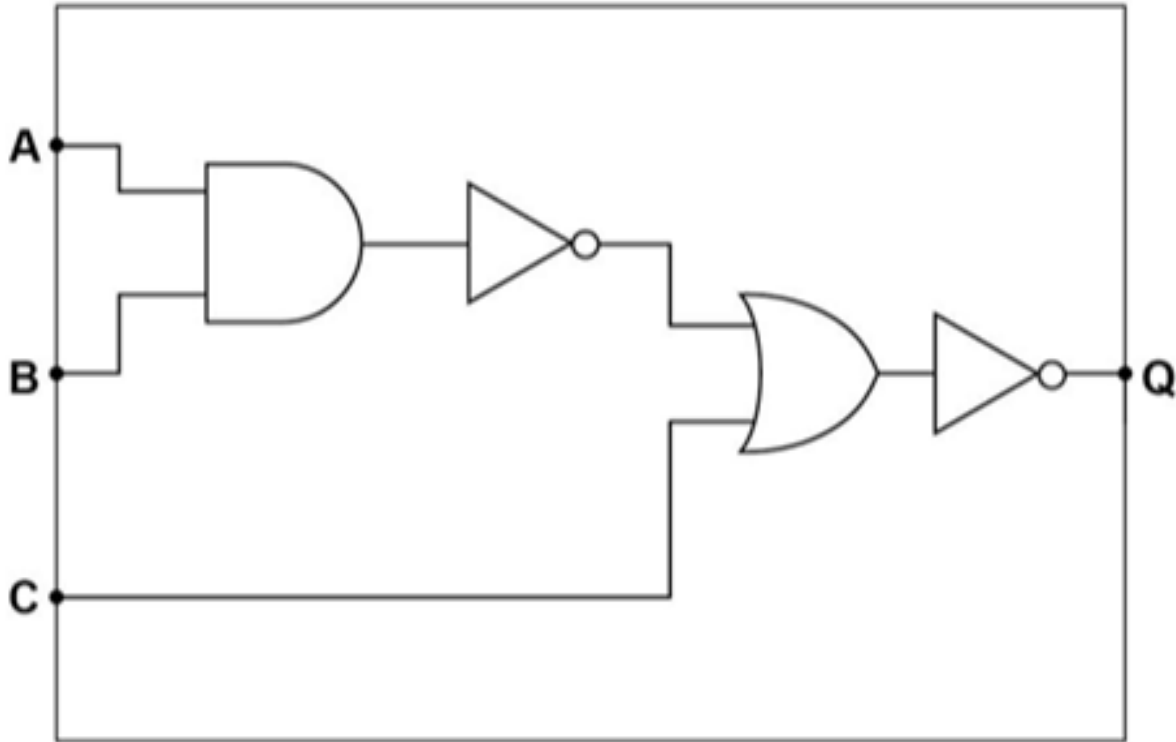

Simplify the combined logic gate?

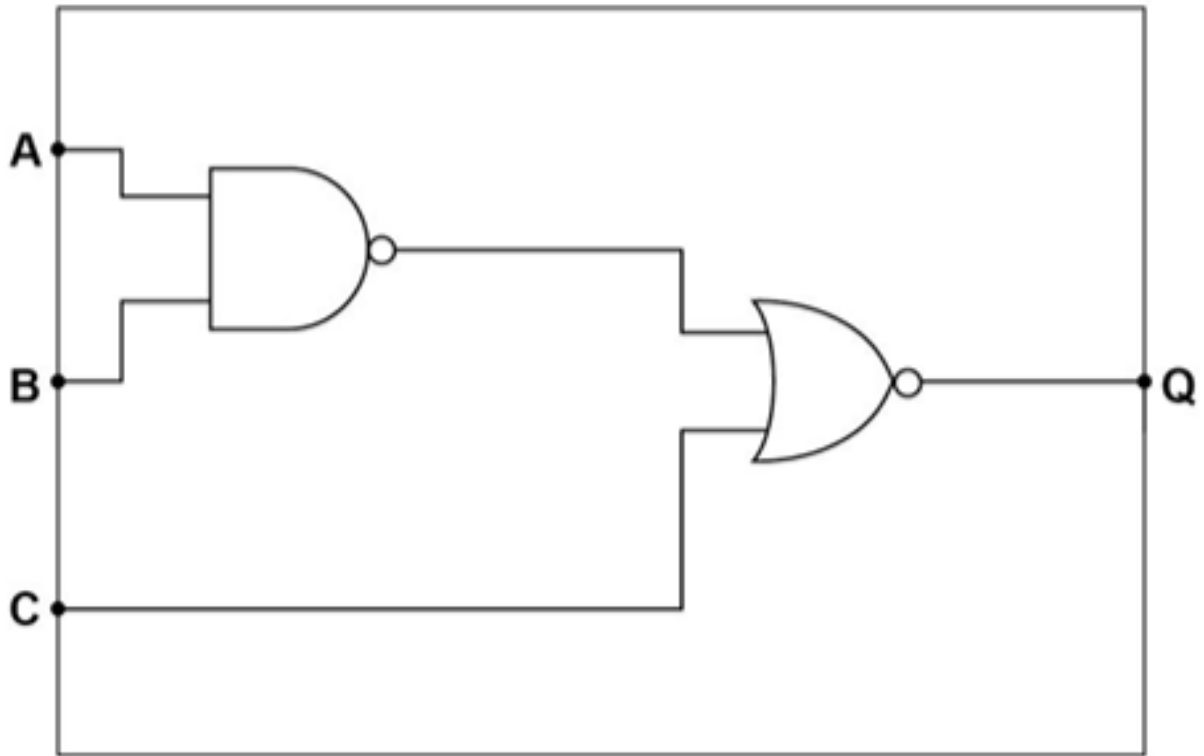

$$Q = \overline{\overline{A \cdot B}} + C$$

Truth Table

Truth Table for $\overline{\overline{A \text{ AND } B} \text{ NOR } C}$:

A	B	C	A AND B	NOT(A AND B)	(NOT(A AND B) OR C)	NOT((NOT(A AND B) OR C))
0	0	0	0	1	1	0
0	0	1	0	1	1	0
0	1	0	0	1	1	0
0	1	1	0	1	1	0
1	0	0	0	1	1	0
1	0	1	0	1	1	0
1	1	0	1	0	0	1
1	1	1	1	0	1	0

$$Q = \overline{\overline{A \cdot B} + C}$$

What is the difference between a Stack and a Queue?

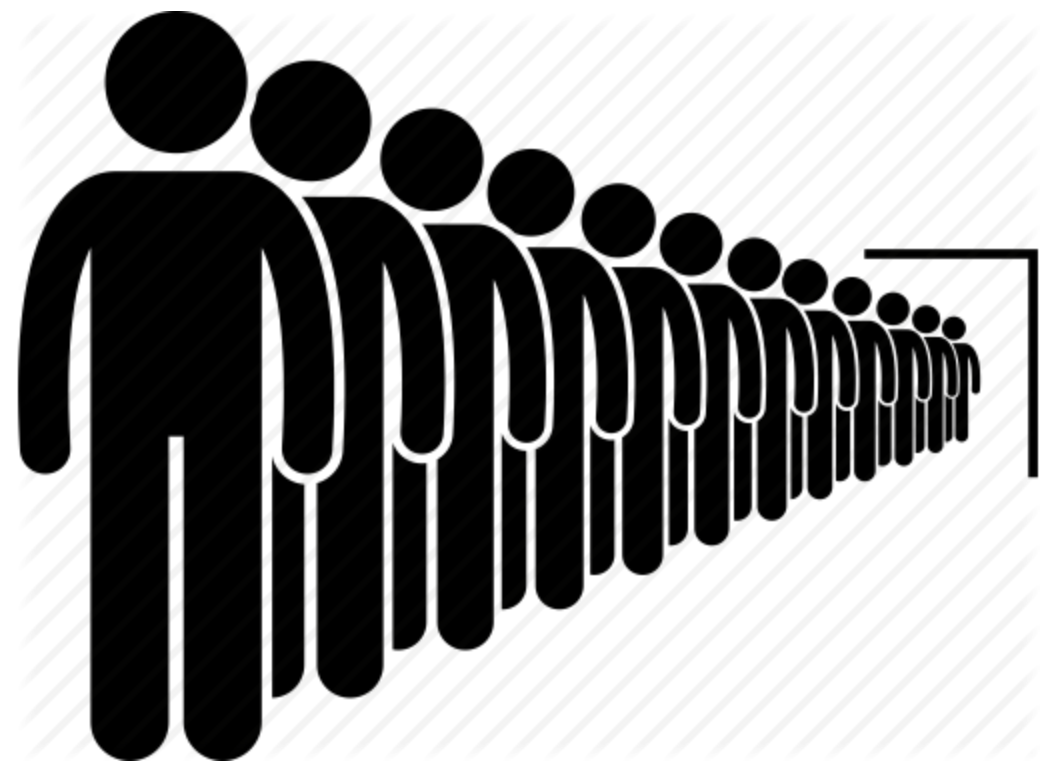

A team of programmers develop software to control a fleet of driverless cars, providing a taxi service for clients in a large city. What Legal and Ethical issues might the programmers face should the public use this service?



The OCR A-level – Entry Requirement

**Grade 6 in GCSE Computer Science,
Grade 6 in Maths plus a minimum
Grade 4 in English Language.**

The OCR A-level – 2year course

Unit 1 Computer systems:

Unit 1.1: The characteristics of contemporary processors and storage devices

Unit 1.2 Software and software development

Unit 1.3 Exchanging data

Unit 1.4 Data types, data structures and algorithms

Unit 1.5 Legal, moral, cultural and ethical issues

Unit 2 Algorithms and programming :

Unit 2.1 Elements of Computational Thinking

Unit 2.2 Problem Solving and Programming

Unit 2.3 Algorithms

Unit 3 – NEA - Programming Project

Coursework – Personal Project

- Program something of interest to you.
- In recent years we've had:
 - Video Games
 - Machine Learning
 - Procedurally Generated Landscapes
 - Satellite Simulators
 - Mobile Apps
 - Tools for other hobbies

Coursework – Project Examples

A Level
Computer
Science

Analysis

The Problem
 Research the GCSE mathematics can be difficult and demanding task many students finding topics boring and difficult to understand. Students that I've talked to find motivation to be able to do the majority of what is required. Some students like the idea of being able to make a game, but they don't know how to do it. Some students are happy to make a game, but they don't know how to do it. Some students are happy to make a game, but they don't know how to do it. Some students are happy to make a game, but they don't know how to do it.

Design

Problem Decomposition
 Using the problem decomposition technique, the problem is broken down into smaller, more manageable parts. This allows the student to focus on one part of the problem at a time, rather than trying to solve the entire problem at once. The student can then work on each part individually, and then combine the solutions to solve the overall problem.



Clients/Stakeholders

For the project, I will be in contact with my stakeholders that will each provide me with their own set of requirements. My stakeholders will also be responsible for providing me with their own set of requirements that will be used to guide the development of the game.

1. The health bar shows the player's current health. 2. The score bar shows the player's current score. 3. The enemy's health bar shows the enemy's current health. 4. The enemy's score bar shows the enemy's current score. 5. The enemy's name shows the enemy's name. 6. The enemy's status shows the enemy's current status.

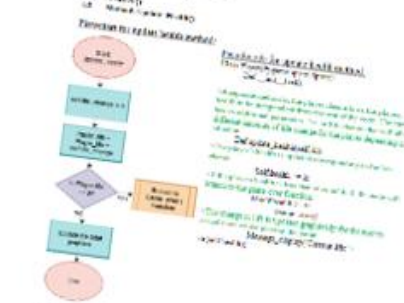

Table with 3 columns: ID, Name, and Description. It lists various game assets and their details.

ID	Name	Description
001	Background	Background image for the game.
002	Character	Character sprite for the player.
003	Enemy	Enemy sprite for the game.
004	Item	Item sprite for the game.
005	UI	UI elements for the game.
006	Sound	Sound effects for the game.
007	Music	Background music for the game.
008	Logic	Logic code for the game.
009	Gameplay	Gameplay mechanics for the game.
010	Testing	Testing procedures for the game.

What do we expect from you?

- As with any A Level, you will need to show commitment and a strong willingness to work hard. You will also need to have:
 - a logical and analytical mind
 - the ability to meet deadlines
 - an interest in how computers work
 - a desire to make computers do what you want
- You will be expected to commit to at least 5 additional hours per week outside of your timetabled lessons.

Where can it take you?

Computer Science is a highly regarded subject that will help you in any academic setting or with any career that requires an academic background. More specifically Computer Science has strong ties to:

- Software Developer
- Systems Analyst
- Finance
- Chemical Engineering
- Cyber Security/ Crime
- Network Manager
- Civil Engineering
- Electrical Engineering
- Database Administrator
- Mechanical Engineering
- Economics
- App Designer
- Pharmacy
- Forensics

Top 10 Universities for CS



University of Oxford



University of Cambridge



Imperial College London



The University of Edinburgh



UCL



King's College London



The University of Manchester



The University of Warwick



Queen Mary University of London



Lancaster University

Typical Extra Curricular Opportunities

- Visit Bletchley Park – See where it all began with a visit to Bletchley Park
- The British Informatics Olympiad – Pit your Computer Science skills against other computer science students across all of Britain in this prestigious event.
- Bebras Computational Thinking Challenge
- Computer Science in Action – See what the experts in computer science are working on

BLETCHLEY PARK



**British
Informatics
Olympiad**



ttp

Computer Science
in ACTION

FAQs

- Do I have to have the GCSE?
- What is the difference between ICT and Computer Science?
- What if I don't get the grade I need?